



- Triple-glazed door
- Suitable for multiple flue connections
- Inner lining (refractory lining) can be replaced through the fire door
- Equipped with 2 transportation wheels at the back for easy installation.
- For extensive and wise accessory see price list

Optional comfort features



Outside air connector



SMS - Mini



SMS



Tube door



Water technology



Reheater box



Ceramic flue heat exchanger

SH 11 T Wood firing

Specifications

Rated thermal output	kW	11
Output range (depending on the fuel quantity)	kW	4,3 - 12,7
Efficiency	%	82,4
Insulation rear / side walls	mm	80 / 80
Ø Supply air line for external air connection	mm	125
Weight incl. refractories	kg	275
Heat emission through glass	%	10
Convective heat	%	90

Data for chimney sweepers or responsible authority according to DIN EN 13384

Closed operation: A1

Triple value for NWL	Flue gas mass flow	g/s	10,4
	Flue gas temperature downstream of reheater element	°C	270
	Required draught at flue gas connector	mbar	0,12
Triple value for calculation of the ceramic channels	Wood quantity	kg/h	4,2
	*Firing power	kW	15,1
	*Flue gas mass flow	g/s	15,2
	*Flue gas temperature before the secondary unit area	°C	493
	*Necessary conveying pressure at the flue gas connector	mbar	0,15
	*Combustion air requirements	m³/h	35,3

* in relation to the wood quantity

Tested method DIN EN 13229
and in accordance with Regulation Art. 15a B-VG

Testing report nr.: RRF - 29 07 1559



1. BImSchV. level 1



1. BImSchV. level 2



More informations:

SH 11 T

Wood firing

Front view M 1:20

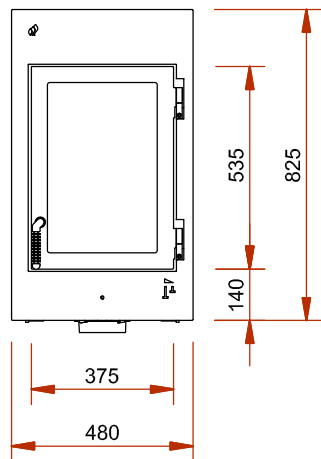

Side view M 1:20

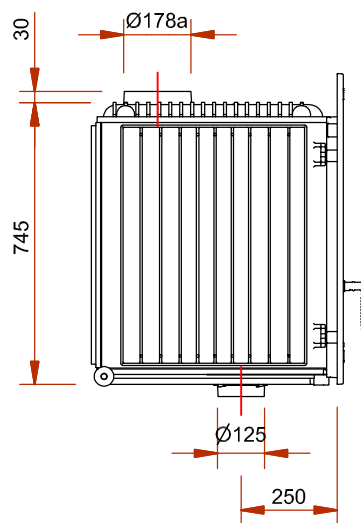

Top view M 1:10

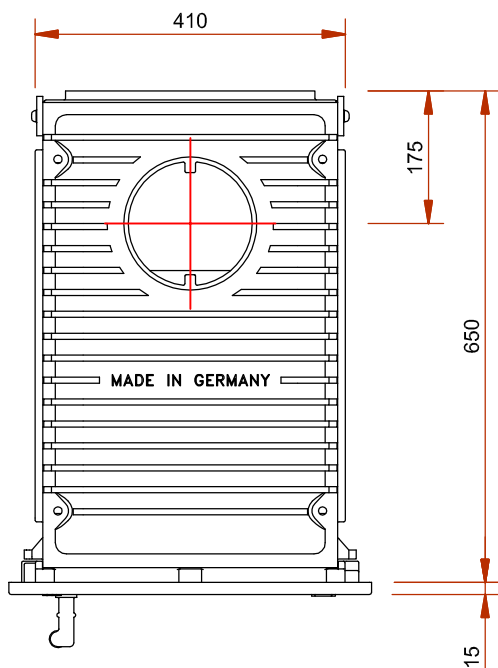

Inner lining

